

GET OFF TO A GOOD START WITH A...



Max-Torque clutches are designed, engineered and manufactured to deliver exceptional performance. They are unique and original in design and engineering.

SMOOTHER • LESS FRICTION • EXTENDED LIFE • EFFICIENT

PARTIAL CLUTCH BREAK DOWN

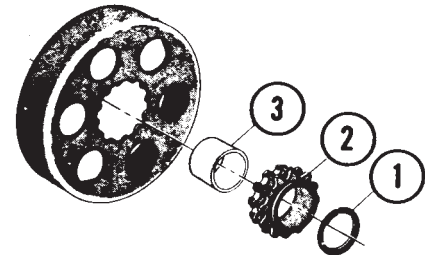

"SS" SPROCKET CLUTCHES

With 3/16" keyway. Two set screw holes 90 degrees apart - tapped 1/4-28.

CAT. #		BORE	TEETH	CHAIN	PITCH
MT1234	\$38.99	3/4"	12T	#35	3/8"
MT1258	38.99	5/8"	12T	#35	3/8"
MT1034	38.99	3/4"	10T	#41	1/2"
MT1058	38.99	5/8"	10T	#41	1/2"
MT1158	38.99	5/8"	11T	#35	3/8"
MT1334	38.99	3/4"	13T	#35	3/8"



SHAFT SNAP RING

Sold each • (Reference #1)

- MT450 \$0.75
3/4" Clutch
- MT452 0.75
5/8" Clutch



SET SCREW FOR MAX-TORQUE CLUTCH

Set Screw (1/4") • Sold Each (Minimum 10)

- MT119 \$0.25



"TRACK TUNED" TT RACING CLUTCH

The "TT" 4 cycle clutch is track tunable to match the modifications made to the engine and the track conditions.

CAT. #		BORE	TEETH	CHAIN	PITCH
MT2334	\$47.99	3/4"	13T	#35	3/8"
MT2534	57.99	3/4"	15T	#35	3/8"



CENTRIFUGAL CLUTCH KEY

3/16" x 3/4" • Sold Each (Minimum 10)

- MT445 \$0.55



BRONZE BUSHING BEARINGS

Reference #3

- MT455 \$2.20
For 3/4" Clutch (7/8" ID)
- MT456 2.20
For 5/8" Clutch (3/4" ID)



MAX-TORQUE PULLEY CLUTCHES

Pulley has a 3.20" O.D. and the clutch drum is 4.2" O.D.

MT32034	\$55.99	3/4" bore
MT32058	55.99	5/8" bore



SPROCKETS

Including Bronze Bushings • Reference #2

- MT462 \$12.90
For 5/8" clutch, 35 Chain, 11 Tooth
- MT463 12.90
For 3/4" clutch, 35 Chain, 12 Tooth
- MT464 10.60
For 5/8" clutch, 35 Chain, 12 Tooth
- MT465 12.90
For 3/4" clutch, 35 Chain, 13 Tooth
- MT468 12.90
For 3/4" clutch, 41 Chain, 10 Tooth
- MT469 12.90
For 5/8" clutch, 41 Chain, 10 Tooth



- helmets & accessories
- apparel
- accessories
- carriers & racks
- bumpers & winches
- plows & implements
- frame & chassis
- utv accessories
- body
- handlebar
- cables & levers
- engine
- fuel & intake
- electrical & ignition
- clutch
- drive
- bearings
- brakes
- suspension & steering
- tires & wheels
- chemicals
- tools
- go cart
- trailer accessories



AUTOMATIC CENTRIFUGAL CLUTCHES

4 Cycle Bikes • Arctic Kitty Cat
Single Sprocket Self-Contained Clutches

SINGLE SPROCKET SELF CONTAINED

Popularity of these four models allows greater production economics without sacrifice of quality and we pass these savings on to you. The 400 Series clutches have more contact surface than most competitors. The 400 Series clutch has built-in staying power. Almost 3-3/4 square inches of steel friction material engagement shoe surface assures positive pulling power as long as the R.P.M. is in full contact range. There's no slipping when you need the "go-power". The 400 Series clutches have continued performance even when they were partly destroyed in torture tests. Bearings have been almost completely worn through by sand and the 400 Series continued to function.

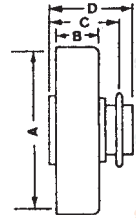

**CSC
400
SERIES**

Engines to 5 HP

Arctic
Kitty Cat
Clutch

209748
\$50.45

CAT. #		TYPE	TEETH	BORE	CHAIN	A	B	C	D
209748	\$50.45	CSC*	11	1 1/2"	5/8	35	4"	1"	1.74 2.22
211627	\$55.29	CSC*	12	1 1/2"	5/8	35	4"	1"	1.74 2.22
209760	\$39.65	CSC*	12	3/4"	3/4	35	4"	1"	1.74 2.22
209768	\$42.15	CSC*	10	3/4"	40/41	4"	1"	1.77	2.22
217636	\$55.95	** E-Z Rider	12	3/4"	35	4"	1"	1.74	2.22
217633	\$55.95	** E-Z Rider	10	3/4"	40/41	4"	1"	1.74	2.22

*COMET SELF CONTAINED

**MAINTENANCE FREE - ONE YEAR LIMITED WARRANTY

4"

**SC
400
SERIES**
Engines to 7 HP

SINGLE SPROCKET SELF CONTAINED

The 400 Series clutch is durable. Designed and built for direct drive mini-bikes, one of the most rugged applications of a modestly-priced automatic centrifugal clutch. Having extra ability for rough service, 400 Series Clutches are known to stand up better when the going gets rough. Sand, grit, gravel and dirt are taken in stride with the 400 Series clutch. Operates under conditions that would destroy most clutches.

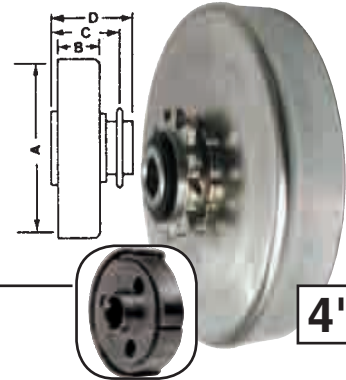

CAT. #	TEETH	BORE	CHAIN	A	B	C	D
N/A	12	1"	35	4"	1"	1.66	2.03
216471	\$98.75	13	3/4"	35	4"	1"	1.45 2.33



SCP 350 SERIES - AUTO CENTRIFUGAL CLUTCHES SELF CONTAINED SINGLE PULLEY

Comet 350 series clutches are leaders of their class when it comes to durability. Their design and rugged construction is the reason. Ratings for all parts are much higher than will ever be required in normal service.

SCP350 PULLEY DRIVEN CLUTCH • 202312 \$81.70 • 1" BORE • 3" PULLEY • 1/4" KEY

400 SERIES - AUTO CENTRIFUGAL CLUTCHES

SINGLE SPROCKET / TWIN SPROCKET

**400
SERIES**
Engines to 8 HP

Use the 400 Series for 4 cycle engines only to 8 H.P. "Straight Centrifugal" rotor action provides slipping range into smooth, non-aggressive engagement with operational RPM's of approximately 2,000 through 3,500. Ideal for high-inertia applications such as mini-bikes, go-karts, etc. Ease of installation and maintenance makes the 400 Series clutch a favorite with thousands of mini-bikers and others who have tough service application requirements.

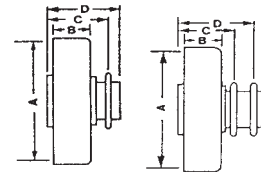

CAT. #		TEETH	KEYWAY	BORE	PITCH	A	B	C	D
203963	\$105.55	11	3/16	3/4	35	4"	1"	1.73	2.04

4"



BRAKE SYSTEMS

BAND ONLY CAT#		SPECIFICATIONS				
		A*	B	C	D	E
10945	\$21.95	2-1/2	1-1/2	3/8	3/4	1/8 Slot
10987	\$26.60	3-3/4	1-3/8	3/8	3/4	5/32 Slot
10951	\$28.95	4"	1-1/2	3/8	1"	1/8 Slot
202127	\$29.80	4-11/16	1-1/2	3/8	7/8	1/8 Slot

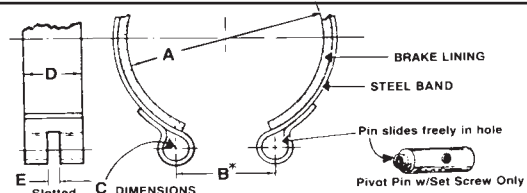

* NOTE: This is a reference dimension with band locked in position around "A" diameter of drum.

BRAKE BAND

Brake band for our 485 brake drum
* Does not come with pin

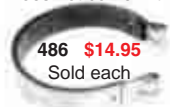

486 \$14.95
Sold each

PIN ONLY

Pin only for our 486 brake band

8200 \$3.35

Sold each



BRAKE DRUM

Sold each • Universal hole pattern 4.22" OD
For 4 wheel or hub stub on 2" square • Universal mounting holes for either 5/16" or 3/8" holes.



485 \$7.95

helmets & accessories

apparel

accessories

carriers & racks

bumpers & winches

plows & implements

frame & chassis

utv accessories

body

handlebar

cables & levers

engine

fuel & intake

electrical & ignition

clutch

drive

bearings

brakes

suspension & steering

tires & wheels

chemicals

tools

go cart

trailer accessories

GO CART

MODEL 20 / 30 SERIES TORQUE CONVERTER SYSTEM

USE ON ALL ENGINES THRU 7HP / SOME APPLICATIONS TO 8HP

20 SERIES

Symmetrical

CAT. #	DESCRIPTION	
219560 \$121.58	Driver	1" Bore
219463 105.85	Driven	3/4" Bore x 6" Dia.



USES 3/4" BELT

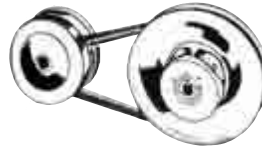

30 SERIES

Asymmetrical

CAT. #	DESCRIPTION	
219465 105.85	Driven	3/4" Bore x 6" Dia.

RECOMMENDED BELT SPECIFICATIONS

40 SERIES: • 7/8" TOP WIDTH • 40 DRIVER - W/40/44 DRIVEN • KEVLAR TYPE • .45 THICK



COMET CAT#	COMET #	40 C.D.	44 C.D.
203790 \$48.35	40-120	11-1/2"	10-9/16"
204331 56.20	40-140	13-3/4"	12-5/8"

DRIVE BELTS FOR 20/30 SERIES UNITS

6" & 7" DIAMETER UNITS • 3/4" TOP WIDTH



FOR PARTS BREAKDOWN OR SHEETS FOR INFORMATION - CONTACT OUR OFFICE

SYMMETRICAL CAT.. #	MARKED ON BELT	6" DIAMETER DRIVEN	7" DIAMETER DRIVEN	OUTSIDE DIAMETER	ASYMMETRICAL CAT. #	MARKED ON BELT
----	884-70	6-15/16 - 7	No Fit	27.36	203589	994-70
----	884-105	9-15/16 - 10	9-3/16 - 9-1/4	33.78	203596	994-105

COMET'S TORQ-A-VERTER KIT

FOR MINI-BIKES & GO CARTS USING 4 CYCLE ENGINES

- Converts direct drives into high performance fun machines in minutes
- No welding
- No misalignment
- No guesswork
- No adjusting of belt centers
- Just bolt on the Torq-A-Verter and take off!
- This kit includes 1 each: mounting bracket with sprocket, 1 bag of hardware, driver, belt, cover

RECOMMENDED TO 8 HP MAXIMUM



SPROCKETS FOR TORQ-A-VERTER

10 Tooth, 5/8" Bore, 1/2" Pitch. Replacement sprocket for Torq-A-Verter. 41/40 chain.

202168	\$29.90
12 Tooth, 5/8" Bore, 1/2" Pitch. Replacement sprocket for Torq-A-Verter. 35 chain	
200379	\$22.80

IMPORTANT!

Torque Converter DRIVE UNIT MUST NOT FLOAT on engine crankshaft. It must be bolted tight against engine crankshaft shoulder. Recommended torque for bolt: 24 ft. lbs. to 30 ft. lbs. max.

CAT#	CRANKSHAFT SIZE	# OF TEETH	CHAIN SIZE	REPLACE BELT
218353 \$242.99	3/4"	10 T	#40-41	205389



MANCO TO COMET CROSS REFERENCE

MANCO NO.	COMET #	MANCO NO.	COMET #
1154	200393A	5959	203589A
2433	203783A	6814	203784A
2795	203588A	9659	203590A
3619	203792A	8192	203593A
4292	203580A		



COMET DRIVE SYSTEM CONVERSION FOR THE HONDA ODYSSEY

This system completely converts your original torque converter drive system and features simplicity, ruggedness and lasting performance. This is a great system for the occasional racer and the person weary of constant drive system maintenance and expense.

All components of this conversion kit are ready to "bolt-on". Kit includes **94C - 209234** drive clutch, **209451** belt and **90D - 212371** driven "T.C." (readily accepts transfer of Odyssey brake disc). 94C calibration: 6 pucks **206143** and white spring - **205820**.

FOR COMPLETE PARTS LIST - CALL OUR OFFICE



94C CLUTCH - 90D DRIVEN **209187 \$483.70** 1-1/4" Wide Belt FL250 Only

APPROXIMATE ENGAGEMENT 4600 RPMs



TIPS FOR PROPER BELT ADJUSTMENT USING 6" OR 7" DRIVEN UNITS



1. Select belt for nearest approx. shaft setting. 2. Check belt tension. Belt should be at its highest point in the driven pulley flanges. Remove outer half of driven clutch. Squeeze belt down and pull forward as shown. Position engine so that 1/8" to 3/16" of clearance is provided around clutch bushing/hub. NOTE: By increasing the spring tension of the torque system...the power ratio of the system (driver and drive) is held longer at higher engine rpm's before it is overcome by driver. To shorten the time required for the driven member to attain ratio, DECREASE the amount of spring tension of the torque cams. This will allow the rpm of the drive clutch to move power ratio of the driven unit at a faster rate in a lower rpm.

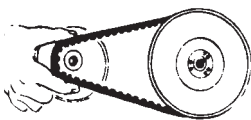

DRIVE BELTS FOR T.C. 88/C.A.T. 99 SERIES UNITS

6" & 7" DIAMETER UNITS • 5/8" TOP WIDTH

T.C. 88 SERIES CAT. #	MARKED ON BELT	6" DIAMETER DRIVEN	7" DIAMETER DRIVEN	OUTSIDE DIAMETER	C.A.T. 99 SERIES CAT. #	MARKED ON BELT
200419 \$28.95	883-70	6-15/16 - 7	No Fit	27-23/64	----	993-70
----	883-80	7-9/16 - 7-5/8	6-13/16 - 6-7/8	29-9/32	200395 \$28.95	993-80
200423 28.95	883-90	8-11/16 - 8-3/4	7-3/4 - 7-13/16	31-15/64	----	993-90
----	9-3/16 - 9-1/4	8-5/16 - 8-3/8	----	32-13/64	200398 28.95	993-95
200425 28.95	883-100	9-5/8 - 9-11/16	8-3/4 - 8-13/16	33-11/64	----	993-100

DISC CALIPER BRAKE

This brake can be used on snowmobiles, go-karts, mini-bikes, garden tractors and numerous industrial applications. The brake has 1.9 square inches of replaceable automotive brake material and can be set in 8 different lever positions and pulled from either direction. Caliper and disc must be ordered separately.



CAT#	DISC & HUB
212369 \$40.05	6-3/8" dia., 1" bore, 1/4" keyway with set screw
212396 56.20	10" dia., 1" bore, 1/4" keyway with set screw

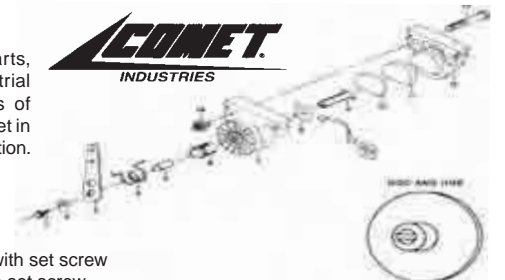

MINI BIKE THROTTLE CONTROLS

Twist Grip • Metal
Deluxe throttle controls which come complete with twist grip and dummy grip.



257	7/8" Tubing	\$22.95
258	1" Tubing	17.50

BRAKE-THROTTLE CABLE

UNIVERSAL • 100" INNER CABLE • 92" CASING • 3/16" BARREL
• This universal cable has an extra length for some snowmobiles, atvs, go carts and mini bikes
• Comes complete with outer casing



269 **\$6.75**

MINI BIKE / UNIVERSAL THROTTLE CABLES

This cable comes complete with inner cable and housing. It also has a ball on one end, barrel on the other.



261	48" inner / 43" casing	3/16" Barrel	\$2.60
262	53" inner / 48" casing	3/16" Barrel	2.70
263	60" inner / 55" casing	1/4" Barrel	2.95

WIRE STOP

Wire Stop. Used for securing inner wire to engine. Sold each.



LP05902 **\$0.95**

MINI BIKE WIRE SWIVEL STOP

This universal wire stop will work on throttles and brake cables. It will also work as a wire swivel.



267 **\$0.95**

MINI-BIKE BRAKE CABLE

UNIVERSAL • 65" INNER CABLE • 60" CASING • 3/16" BARREL
• This is a universal cable
• Heavy duty for long wear
• Comes complete with outer casing



264 **\$2.90**

IMPORTED INDUSTRIAL RIVETED ROLLER CHAIN AND LINKS

ROLLER CHAIN
Sold in 10' or 100' lengths only



10' Length			100' Length		
CHN25	#25	\$25.80	1/4" x 1/8"	----	
CHN35	#35	21.60	3/8" x 3/16"	CHN3510	\$210.00
CHN40	#40	24.75	1/2" x 5/16"	CHN4010	235.00
CHN41	#41	16.90	1/2" x 1/4"	CHN4110	164.40
CHN42	#42	19.55	1/2" x 3/16"	----	
CHN43	#43	16.10	1/2" x 1/8"	----	
CHN50	#50	38.80	5/8" x 3/8"	----	
CHN60	#60	49.05	3/4" x 1/2"	----	
CHN420	#420	35.60	1/2" x 44"	----	
CHN428	#428	42.95	1/2" x 5/16"	----	

CONNECTING/OFFSET LINKS
Sold each



Connecting Link		Offset Link	
CCL25	\$0.65	#25 sgl	OSL25 \$1.25
CCL35	0.60	#35 sgl	OSL35 1.10
CCL40	0.55	#40 sgl	OSL40 1.10
CCL41	0.55	#41 sgl	OSL41 1.15
CCL42	0.65	#42 sgl	OSL42 1.35
CCL43	0.65	#43 sgl	OSL43 1.15
CCL50	0.95	#50 sgl	OSL50 1.65
CCL60	1.25	#60 sgl	OSL60 2.00
CCL420	1.00	#420 sgl	OSL420 1.85
CCL428	1.00	#428 sgl	OSL428 1.75

NICKEL PLATED ROLLER CHAIN LINKS

Sold each

OFFSET LINK	DESC.	
02-398	#35 sgl.	\$1.50
02-396	#41 sgl.	1.50



QUAD STAKE RIVET KIT

• The perfect compliment to the 678135 Jumbo Chain Tool (below) • Retain that factory Quad stake look • Safely and properly peens soft-nose-type masterlink pin tip.



678142 **\$15.45**

JUMBO CHAIN TOOL

• Designed to break and / or rivet roller chain • Masterlink sideplate press kit included • Fits all 520, 525, 530, 630 standard or O-ring type chain • Will also service industrial chain from #50 through #80 • Screws and attachments are made from 86L20 steel and then heat treated for strength and durability • The extractor pin is firmly guided by a removable guide, ensuring long pin life • May be bolted to a workbench, supported in a vise or held by the handle • When bolted to a solid surface, air or electric wrenches may be used to break chain • Recommended for heavy duty use.

JUMBO CHAIN TOOL	678135	\$139.95
REPLACEMENT PIN	678135D	9.70

Motion Pro



helmets & accessories

apparel

accessories

carriers & racks

bumpers & winches

plows & implements

frame & chassis

utv accessories

body

handlebar

cables & levers

engine

fuel & intake

electrical & ignition

clutch

drive

bearings

brakes

suspension & steering

tires & wheels

chemicals

tools

go cart

trailer accessories

GO CART

helmets & accessories

apparel

accessories

carriers & racks

bumpers & winches

plows & implements

frame & chassis

utv accessories

body

handlebar

cables & levers

engine

fuel & intake

electrical & ignition

clutch

drive

bearings

brakes

suspension & steering

tires & wheels

chemicals

tools

go cart

trailer accessories



CHAIN DETACHER

A handy tool to remove and replace pins in chain links - lightweight - heat treated.



CHAIN DETACHER 1733 **\$17.75**
REPLACEMENT PIN ONLY 1729 **2.40**

CHAIN BREAKER

• For 420 to 630 chain • Will push link pin completely through link • Handle folds away for easy storage • Replaceable pin is heat treated for strength and wear resistance.



CHAIN BREAKER 678001 **\$29.95**
PIN ONLY 678002 **3.85**

MINI CHAIN PRESS TOOL

• Fits most 520 - 530 standard and O-ring chains • Tool box or fanny pack size • Hex key wrench is included with tool.



678070 **\$16.95**

CHAIN PRESS TOOL KIT

• Fits 520 - 530 standard and O-ring chains.



CHAIN PRESS TOOL KIT 678066 **\$51.95**
PRESS PLATES ONLY 678067 **17.20**

CHAIN ALIGNMENT TOOL

• Quick and accurate alignment • Tool body clamps squarely to rear sprocket so the alignment rod will indicate sprocket alignment.



678048 **\$51.95**

TUBE TYPE KART SLICK TIRES • IMPORTED

CAT. #	SIZE	PLY RATING	TREAD	RIM WIDTH	O.D.	WIDTH	PSI	
693403	410/350-4	4	Slick	2-3/4"	10.5"	3.5"	20#	\$7.50
693420	11/360 - 6	4	Slick (HD)	---	---	---	---	12.50

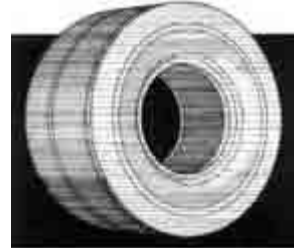

KART WHEELS

Air Tires - 2 Piece Split Rim - 14 Gauge
4 Hole - 2 13/16" Bolt Circle - 2" Center Hole (5/16" Bolt Hole)
NON-HIGHWAY SERVICE (NHS)

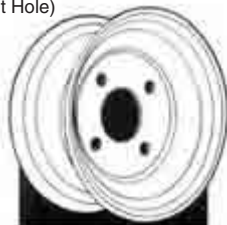

CAT. #	RIM DIA.	WIDTH	FITS TIRE SIZE	
690800	4"	2-1/8"	280-4	\$7.50
690801	4"	2-3/4"	410-4	7.50
690802	5"	2-3/4"	350-5; 410-5	9.50
690803	6"	----	----	9.50

HEAVY DUTY INDUSTRIAL BEARING

Sold each



CAT#	ID	OD	OL	
325	1/2"	1-3/8"	7/16"	\$1.85
326	5/8"	1-3/8"	7/16"	1.70
327	3/4"	1-3/8"	7/16"	1.70

AEROSOL CHAIN SPRAY

Excellent with rubber 'o-ring' chain sprays. Upside down or right side up. Cleans, lubricates and protects. Use for competition or touring.



KL605 **\$9.25** Sold each 16 oz.



ENGINE/JACKSHAFT SPROCKETS

3/16" KEY • 5/16-18 SET SCREW



#35 CHAIN 5/8" BORE		
472	\$8.50	12 tooth
473	8.50	14 tooth
474	9.50	16 tooth